

# OWNER'S MANUAL

# DMC

# COMBINE Calc-U-Dri I

PNEG-1140

Date: 9-21-06



PNEG-1140



**CAUTION  
BE A SAFE OPERATOR**



1. Read and understand this Owner's Manual
2. Stop the combine threshing unit and engine before sampling, adjusting or servicing.

**Use caution when obtaining a sample from the grain hopper. Follow combine manufacturer's recommendations when climbing in and out of the hopper.**

3. Disconnect all electrical power before servicing or opening control box.
4. Ground all electrical equipment properly.
5. Only knowledgeable and trained personnel should operate this equipment.

**FAILURE TO FOLLOW THESE INSTRUCTIONS  
MAY RESULT IN PERSONAL INJURY OR PROPERTY DAMAGE.**

## COMBINE CALC-U-DRI INTRODUCTION

Congratulations on the purchase of your new Combine Calc-U-Dri Grain Moisture Monitor from DMC. The Calc-U-Dri utilizes DMC's years of experience with grain moisture monitors and controls in the grain drying industry. Your new Combine Calc-U-Dri was designed by DMC's engineers who also farm and utilize the equipment in their farming operations. Since the Calc-U-Dri was designed for farmers, you can be assured that the Calc-U-Dri was designed specifically for your needs.

The DMC Combine Calc-U-Dri will monitor grain moisture as it enters the combine hopper. It will also signal when the moisture content is at or higher than a preset level as set by the operator. The digital display can be mounted in any location for convenience. The display will constantly show grain moisture content. It will show temperature upon demand.

The Combine Calc-U-Dri can easily be calibrated for use on various models of combines and different grains by using the moisture offset feature. If you ever have any questions on the function, design or operation of DMC's Combine Calc-U-Dri, contact your nearest DMC Sales & Distribution Center or DMC's Factory in Mason City, Iowa. (See the listings on the back cover.)

## OPERATION

1. The Combine Calc-U-Dri Control Box is designed to be mounted to the ceiling of a combine cab. The owner's manual can be folded and stored in the space between the ceiling and the box. Always refer to the Owner's Manual for installation and operating information. See Photo A.



**Photo A**

2. Turn the combine ignition switch to the "on" or "accessory" position. Switch the Combine Calc-U-Dri power switch "ON". The digital display should read approximately 2.0% with the offset off when there is no grain on the sensor. Or, it will read the moisture content of any grain that is left on the sensor.
3. Push the mode selector switch up to the temperature position and the digital display will read the temperature of the grain on the sensor. Normally, this will be close to the ambient temperature.
4. Push the mode selector switch down and the digital display will read the moisture limit. Turn the moisture limit adjustment knob **clockwise and the limit will increase**. Turn the knob **counterclockwise and the limit will decrease**. If the moisture limit is below the moisture content of the grain, the red light on the digital display will be lit.

**OPERATION** (continued)

5. Switch the power switch to “ON” with ALARM”. An audible alarm will sound and the red indicator will light when the moisture content of the grain reaches the moisture limit setting. The alarm will last about one-half second and will sound each time the moisture limit is reached. With the power switch in the “ON” position, only the red indicator will light to alert the operator when the moisture limit is reached.
6. The Combine Calc-U-Dri unit needs to be calibrated for different grains and auger configurations. This is done by comparing the moisture reading on the digital display with the moisture reading from a reliable moisture tester.

**NOTE:** It is important to take samples when the readings are steady and not changing rapidly and to use the average of several samples when calibrating the unit to insure accuracy. See sample procedure on page 11.

Unlock the counter by moving the lever on the bottom of the counter to the left, then dial in the difference between the two readings. Turn the offset switch to the “Subtract” position if the digital display reading was too high or the “Add” position if the display reading was too low. The switch is left in the “Add” or “Subtract” if needed. Record the offset number used for each grain in the back of this manual for future reference. See inside back cover for initial calibration settings when switching from one grain to another.

7. On combines where the sensor is mounted in a horizontal tube, the sensor should be removed from the auger tube and the grain cleaned out before storing the combine between seasons.

Combine Calc-U-Dri I Parts

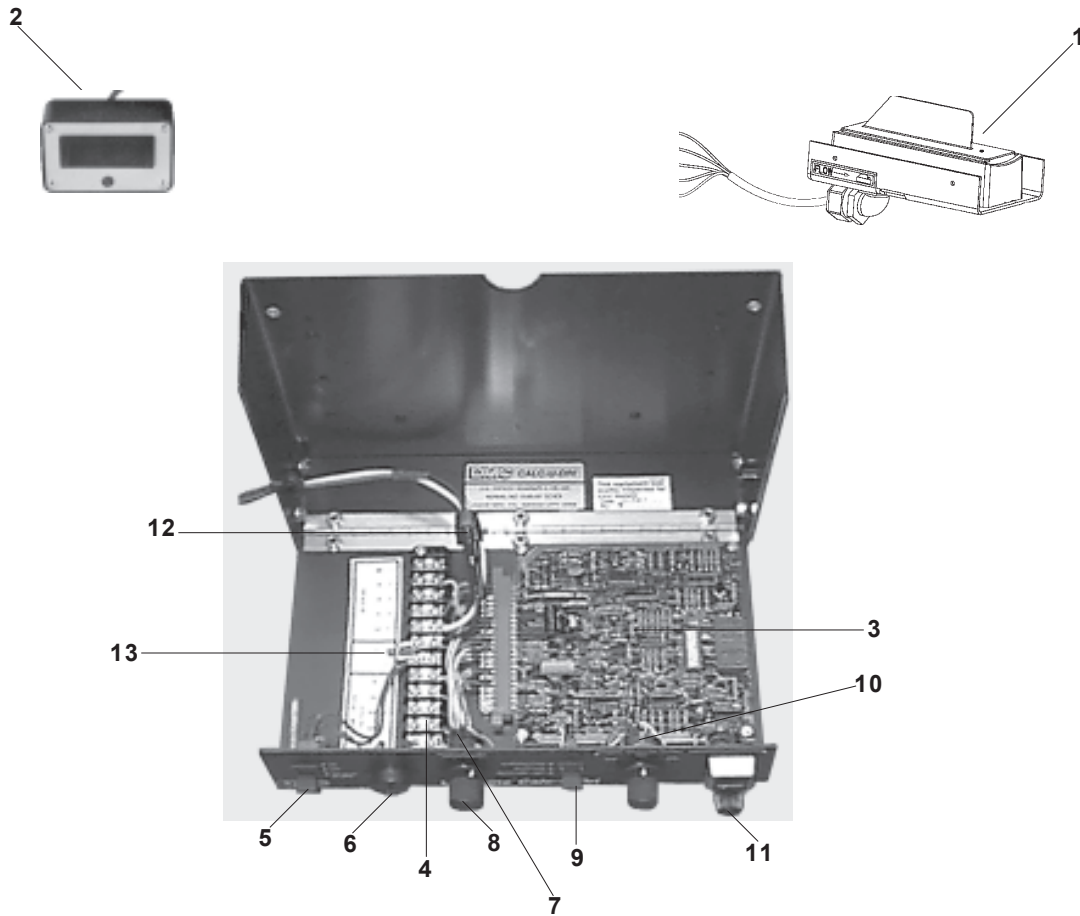

**COMBINE CALC-U-DRI PARTS**

Ref.#	Part No.	No. Req'd	Description
1.	602E382	1	Calc-U-Dri Sensor, Complete
2.	602E209	1	Digital Display, Complete
3.	602E460	1	DMC "18" Circuit Board
4.	1EL0900	1	Terminal Block, 12 Post
5.	2EL0651	1	Switch, 2 Pole
6.	1EL1477	1	Alarm, Audible
7.	1EL0672	2	Potentiometer
8.	1EL0921	2	Knob
9.	2EL0650	1	Switch, Single Pole
10.	2EL0647	1	Rotary Switch
11.	2EL0295	1	Counting Dial
12.	1EL0719	1	Fuse, 2 Amp
13.	602E454	1	EMI Filter

**Parts Not Shown**

A.	602E091	1	Sensor Clearance Gauge
B.	MS0309	As Req'd	Worm Gear Clamp 38" Long
C.	602E206	1	Wire Harness, Power
D.	1EL2022	As Req'd	"J" Clip
E.	1EL2112	As Req'd	Nylon Tie, 4" Long

---

**CONTROL BOX INSTALLATION**

1. The Combine Calc-U-Dri Control Box is designed to be mounted to the ceiling of the cab or any convenient location. After selecting a location in the cab, check the area above the ceiling for any hoses, tubes or electrical wiring that could be damaged by the Calc-U-Dri mounting screws.
2. Open the Calc-U-Dri box by loosening the screws on the front bottom corner. See Photo B.
3. Hold the box up to the chosen location and mark the mounting holes through the top of the box. See Photo B or Diagram 1. Six holes are provided in the Calc-U-Dri. Use two or four of the holes to mount the Combine Calc-U-Dri to the combine ceiling, depending on the obstructions in the ceiling and/or the sturdiness of the material from which the ceiling is made. Pilot holes (9/64" diameter) can be drilled, or the self-tapping screws that are provided, can be used to secure the box to the ceiling. Double check to make sure that no components can be damaged in the area by the mounting screws.
4. For installations where the control box is to be mounted to a flexible surface, it may be desirable to use a back-up plate or brackets to stiffen the mounting surface. Use the cover of the control box as a template to mark the location of the six (6) mounting holes on the back-up plate or brackets. Drill 0.140 diameter (9/64") holes in the back-up plate as pilot holes for the self-tapping screws that are provided for mounting the box.

When the control box is mounted to a surface or panel that is held in place with spring clips or other quick-latch devices, make sure that the additional weight (about 4-1/2 lbs.) of the control box will not cause the panel to fall. It may be necessary to use additional mounting screws for the panel or to attach a safety chain to insure that if the panel does become loose it will not obstruct operation of the combine.

5. Select a location for the digital display such as the back side of the steering column. Clean off the mounting surfaces with wood alcohol to remove any oil or dust before sticking the display to the surface. See Diagram 2.
6. Use the stick-on clips to route the cable from the digital display to the Calc-U-Dri control box.
7. Feed the cable through the grommet on either side of the box and, leaving about 10 inches for connections, cut off any excess cable.
8. Separate the individual wires in the cable, remove one-quarter inch of insulation on each wire and connect them to the terminal block posts as marked by the decal (i.e., white to eight, green to nine, black to ten, brown to eleven and red to twelve).
9. Feed the power supply wire through the same grommet and route them to a convenient power source in the cab. Make sure that the red wire is connected to the positive (+) side (+12 volts) and the white wire is connected to the ground (-) side. Pick up power from a source that is controlled by the ignition switch such as the radio circuit. Use stick-on clips to route the power supply wires. See Photo C.

**CONTROL BOX INSTALLATION** (continued)

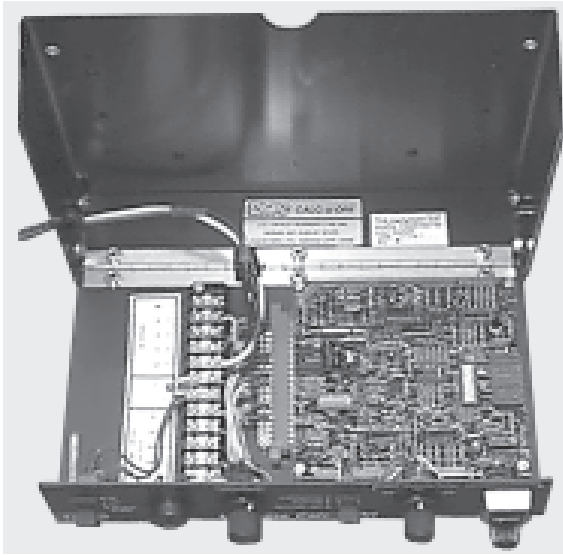

**Photo B**

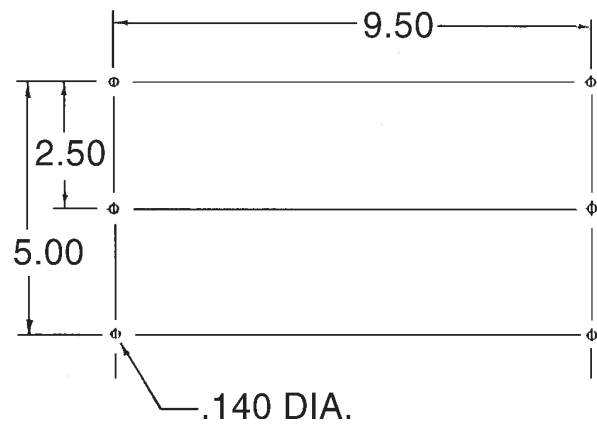

**Diagram 1**

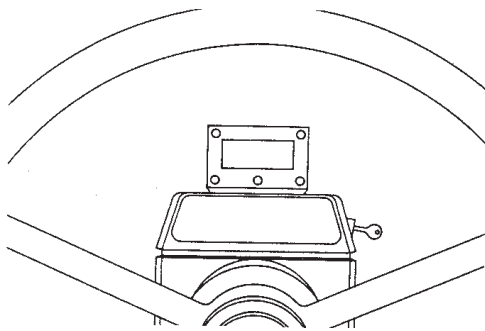

**Diagram 2**

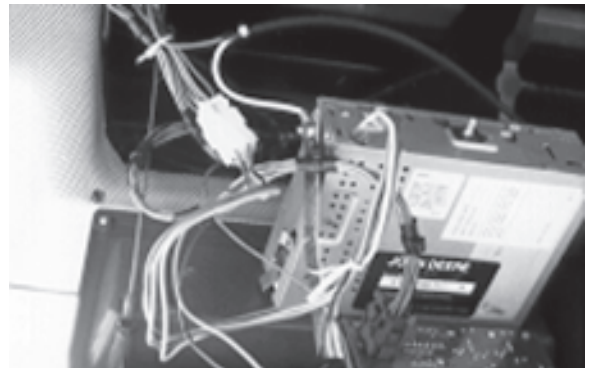

**Photo C**

## SENSOR INSTALLATION

1. The sensor should be mounted in the bottom of the clean grain auger tube in the combine grain hopper. Use the template provided to mark a 5-11/16" x 1-11/16" rectangle on the bottom of the tube about 12 inches from the end of the tube to the center of the hole. The template may then be discarded. Cut this rectangle out carefully to make sure that the sensor block fits tight. **DO NOT TORCH THE CUT EDGE.** See Photo D.
2. Mark the flighting that sweeps over the sensor hole and disassemble the auger tube from the flighting.
3. Locate the marks made on the flighting above the sensor hole and weld the flighting to the auger shaft 3/8" beyond each end of the marks.
4. Cut approximately six and one-half inches (6-1/2") of flighting out between the welds and smooth out any rough edges on the flighting ends and on the auger shaft. See Photos E & F.

**OPTIONAL:** The flighting cut out may be used to double the flighting thickness on each side of the sensor opening. This is optional and not required.

5. Reassemble the auger tube and check to make sure that the flighting will not hit the sensor blade, inserting the sensor gauge into the sensor hole and rotating the flighting. The gauge should not be touched by the flighting.
6. Insert the sensor into the tube and secure in place with the 38 inch long hose clamp provided. Two of these may have to be spliced together for enough length to go around the auger tube and sensor block. See Photo G.
7. Use a self-drilling screw to attach the ground strap to the auger tube 90° up from the sensor. See Photo G.
8. Make sure that the sensor is oriented properly in the tube. Note the direction of the grain over the sensor blade.
9. Route the sensor cable out of the hopper and to the cab. Use hose clamps to secure the cable to the auger tube if necessary. Use stickon clips and ties to route the sensor wire from the hopper to the cab. See Photo H. A clip-on grommet is provided to seal the cab if a hole must be drilled for entry into the cab. Use a 15/32 inch diameter drill bit for drilling the hole for the grommet.

**NOTE:** It is important when routing cable that it is attached securely against something so that the grain being drawn out of the hopper does not pull on the cable, causing loose or broken connections. See Photo H.

10. Route sensor cable about six inches through the grommet in the Calc-U-Dri box and cut off excess cable.
11. Remove about three inches of cable housing and shield and connect the individual wires to the terminal block posts opposite the decal. (i.e., black to number one, white to number two, blue to number three, red to number four and green to number five.)

**NOTE:** The cable shield should not be attached in the control box. Prevent shield from shorting out by taping any exposed shield.

12. Close the Calc-U-Dri box and tighten the screws in the front corners.
13. Your Combine Calc-U-Dri is now ready for use.

**SENSOR INSTALLATION (continued)**



**Photo D**

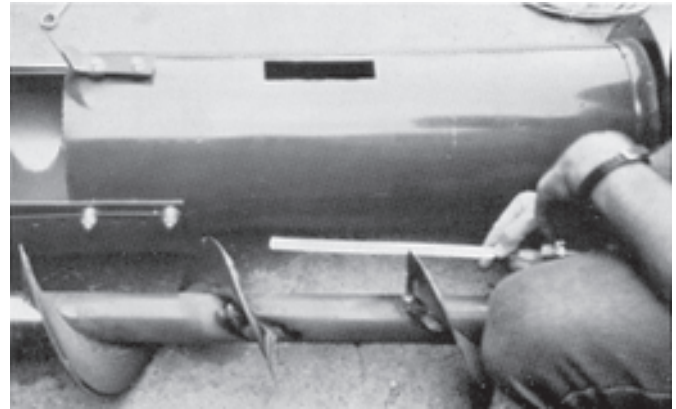

**Photo E**

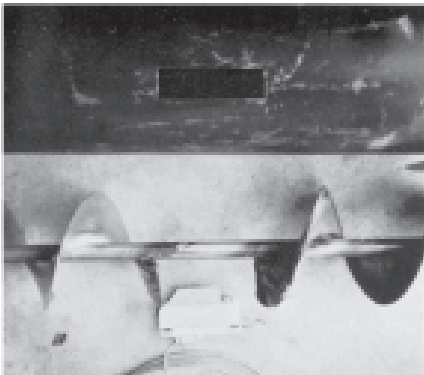

**Photo F**

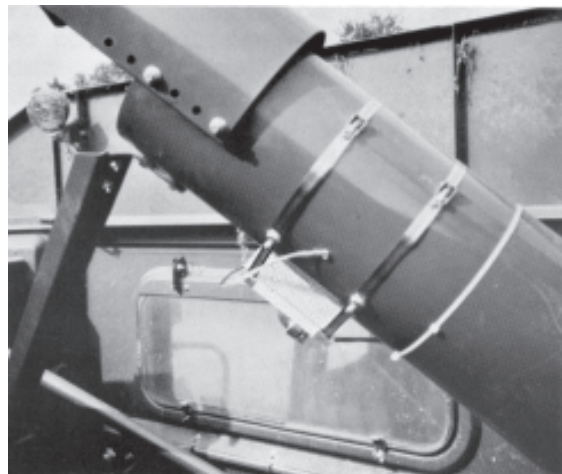

**Photo G**  
**(New sensors have ONE clamp)**

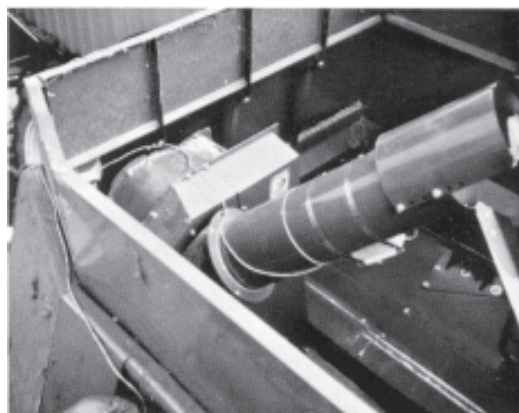

**Photo H**  
**(New sensors have ONE clamp)**

**TROUBLE SHOOTING GUIDE**

PROBLEM	PROBABLE CAUSE	SOLUTION
Digital readout dead	<ol style="list-style-type: none"> <li>1. Ignition switch is off</li> <li>2. Power switch is off</li> <li>3. Control fuse (2 amp) is blown</li> <li>4. Bad circuit board</li> <li>5. Bad digital readout</li> </ol>	<ol style="list-style-type: none"> <li>1. Turn on</li> <li>2. Turn on</li> <li>3. Replace</li> <li>4. Replace circuit board</li> <li>5. Replace digital readout</li> </ol>
Moisture readings are very high but grain checks dry	<ol style="list-style-type: none"> <li>1. Moisture on sensor blade</li> <li>2. Foreign object jammed on sensor</li> <li>3. Offset accidentally set to add</li> <li>4. Sensor not grounded to the tube</li> <li>5. Bad circuit board</li> <li>6. Bad sensor - Temperature reads a negative value.</li> </ol>	<ol style="list-style-type: none"> <li>1. Dry off the sensor</li> <li>2. Remove</li> <li>3. Reset</li> <li>4. Secure ground strap</li> <li>5. Replace circuit board</li> <li>6. Replace sensor</li> </ol>
Moisture readings do not change, temperature readings are high negative	<ol style="list-style-type: none"> <li>1. Sensor leads are broken or not hooked onto the terminal making a good connection</li> <li>2. Bad sensor</li> </ol>	<ol style="list-style-type: none"> <li>1. Tighten terminal screws</li> <li>2. Replace sensor</li> </ol>

**TROUBLE SHOOTING GUIDE** (continued)

PROBLEM	PROBABLE CAUSE	SOLUTION
Moisture readings are intermittently high then low	<ol style="list-style-type: none"> <li>1. Check for the sensor ground strap not hooked up</li> <li>2. Sensor cable leads</li> <li>3. Loose terminal leads where sensor is hooked.</li> </ol>	<ol style="list-style-type: none"> <li>1. Hook up strap</li> <li>2. Replace sensor and cable</li> <li>3. Tighten screws</li> </ol>
Moisture readings are consistently high or low	<ol style="list-style-type: none"> <li>1. Correct by offset adjustment, refer to control box definitions</li> </ol>	<ol style="list-style-type: none"> <li>1. Adjust</li> </ol>
Moisture reading, temperature reading, and moisture limit are all reading the same value	<ol style="list-style-type: none"> <li>1. Control board not functioning correctly</li> </ol>	<ol style="list-style-type: none"> <li>1. Replace control board</li> </ol>
Digital display does not have the green backlite. All digits work O.K.	<ol style="list-style-type: none"> <li>1. Broken wire or bad LCD</li> </ol>	<ol style="list-style-type: none"> <li>1. Replace the complete digital display</li> </ol>
Parts of the numbers or one digit missing on the digital display	<ol style="list-style-type: none"> <li>1. Bad LCD</li> </ol>	<ol style="list-style-type: none"> <li>1. Replace the complete digital display</li> </ol>
Red LED indicator does not come on at moisture limit setting	<ol style="list-style-type: none"> <li>1. Control board dip switch setting is wrong</li> <li>2. Wiring error</li> </ol>	<ol style="list-style-type: none"> <li>1. See page 12 for correct dip switch setting</li> <li>2. Check the 5 wire connections on the terminal for the digital display</li> </ol>

**TROUBLE SHOOTING (continued)**

<b>PROBLEM</b>	<b>PROBABLE CAUSE</b>	<b>SOLUTION</b>
Buzzer does not work	<ol style="list-style-type: none"> <li>1. Power switch in the wrong position</li> <li>2. Control board dip switches not set correctly</li> <li>3. Defective buzzer</li> </ol>	<ol style="list-style-type: none"> <li>1. Power switch must be “down” for the buzzer to work</li> <li>2. Check page 12 for correct setting</li> <li>3. Replace buzzer</li> </ol>
Blowing the control fuse (2 amp AGC)	<ol style="list-style-type: none"> <li>1. DC power wires are crossed</li> <li>2. Sensor wires damaged and shorted to ground</li> <li>3. Control board failure</li> </ol>	<ol style="list-style-type: none"> <li>1. The red wire must be hooked to positive 12 volts. White is hooked to ground.</li> <li>2. Replace the sensor and cable</li> <li>3. Replace the control board</li> </ol>

**NOTE**

1. **Never unplug or plug in the circuit board with power on.**
2. DO NOT make field adjustments on the circuit board. This is a factory adjustment only.
3. Contact your dealer or DMC if you have any questions on the operation or service of your Combine Calc-U-Dri Moisture Monitor.



**SAMPLING PROCEDURE**

**!!CAUTION!!**



**ALWAYS STOP THE COMBINE** (travel, thresher and unload auger) **BEFORE GETTING A SAMPLE.**  
**Ideally, stop the combine engine!**

**BE CAREFUL WHEN CLIMBING INTO THE GRAIN HOPPER.** Follow the combine manufacturer's recommendations.

The following procedure should be done prior to the hopper auger being covered with grain and should be done when the moisture of the grain is at the percentage of which you are most concerned:

1. When readings have been steady and have not been changing rapidly\* for a short period of time, stop the combine. Remember the CAUTIONS above.
- \* Calc-U-Dri's electronics average the grain moisture. Therefore, it is possible for you to have a sample that is either wetter or drier than the meter reading. If the meter is changing rapidly, the chance of obtaining a sample that is wetter or drier than the meter indicates is greater than if the meter is NOT changing rapidly.
2. After seeing a steady reading on the digital panel meter, stop the combine and climb into the hopper and collect a sample of grain from the very top layer of grain. (The grain that was being augered into the hopper when the digital panel meter was being read.) A clean, unused sandwich baggy works well to transport this sample to a reliable moisture tester for comparison. Write the Calc-U-Dri moisture reading on each baggy.
3. Take several samples and take their average.
4. Set the offset using that average.

In the example on the right, the unit had a -2.50 offset before sampling. Based on the sampling example, you would now change that to a -2.20.

\*The type of tester used at grain elevators or terminals. Hand-held units can be used, but under certain ambient conditions, may not be very accurate.

<b>SOYBEAN SAMPLING PROCEDURE</b>	
<b>Combine Calc-U-Dri Digital Display</b>	<b>Reliable Tester</b>
13.2%	13.9%
13.4%	13.1%
13.0%	13.2%
12.9%	13.5%
Total: <u>52.5</u>	<u>53.7</u>
<b>Avg.: 13.1%</b>	<b>13.4%</b>

## Combine Calc-U-Dri I

### Dip Switch Settings for 602E460 DMC-18 Boar DMC 18 (602E4670) Supersedes DMC 8 (602E190)

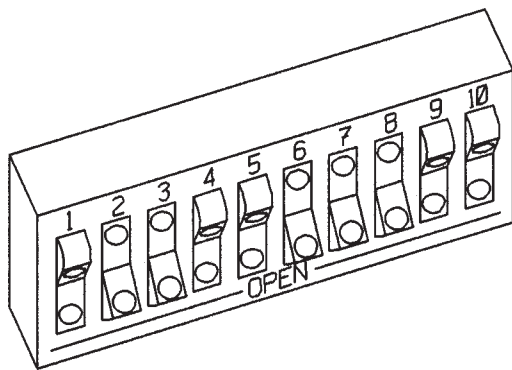

- 1 - OPEN
- 2 - CLOSED
- 3 - CLOSED
- 4 - OPEN
- 5 - OPEN
- 6 - CLOSED
- 7 - CLOSED
- 8 - CLOSED
- 9 - OPEN
- 10 - OPEN

### COMBINE CALC-U-DRI OFFSET RECOMMENDATIONS

The Combine Calc-U-Dri can be used with various grains by calibrating the moisture offset. After determining an offset value for a particular grain and grain condition, log the offset value on the following chart for future reference. A few grains and approximate offset values are already listed to assist with your initial calibration.

GRAIN TYPE	OFFSET	NOTES	YOUR CALIBRATION
Corn	+0.00	18-28% Moisture	
Soybeans	-2.50	10-15% Moisture	
Wheat	-1.50	9-15% Moisture	
Milo	-1.00	12-18% Moisture	
Barley	-0.50	10-18% Moisture	
Oats	-0.50	10-18% Moisture	
Other			

## The GSI Group, Inc. Warranty

THE GSI GROUP, INC. ("GSI") WARRANTS ALL PRODUCTS WHICH IT MANUFACTURES TO BE FREE OF DEFECTS IN MATERIAL AND WORKMANSHIP UNDER NORMAL USAGE AND CONDITIONS FOR A PERIOD OF 12 MONTHS AFTER RETAIL SALE TO THE ORIGINAL END USER. THE PURCHASER'S SOLE REMEDY AND GSI'S ONLY OBLIGATION SHALL BE TO REPAIR OR REPLACE, AT GSI'S OPTION AND EXPENSE, PRODUCTS THAT, IN GSI'S SOLE JUDGMENT, CONTAIN A MATERIAL DEFECT DUE TO MATERIALS OR WORKMANSHIP. ALL DELIVERY AND SHIPMENT CHARGES TO AND FROM GSI'S FACTORY WILL BE PURCHASER'S RESPONSIBILITY. EXPENSES INCURRED BY OR ON BEHALF OF THE PURCHASER WITHOUT PRIOR WRITTEN AUTHORIZATION FROM AN AUTHORIZED EMPLOYEE OF GSI SHALL BE THE SOLE RESPONSIBILITY OF THE PURCHASER.

EXCEPT FOR THE LIMITED WARRANTY EXPRESSED ABOVE, GSI MAKES NO FURTHER WARRANTY OF ANY KIND, EXPRESS OR IMPLIED, INCLUDING, WITHOUT LIMITATION, WARRANTIES OF MERCHANTABILITY OR FITNESS FOR A PARTICULAR PURPOSE OR USE IN CONNECTION WITH (I) PRODUCT MANUFACTURED OR SOLD BY GSI OR (ii) ANY ADVICE, INSTRUCTION, RECOMMENDATION OR SUGGESTION PROVIDED BY AN AGENT, REPRESENTATIVE OR EMPLOYEE OF GSI REGARDING OR RELATED TO THE CONFIGURATION, INSTALLATION, LAYOUT, SUITABILITY FOR A PARTICULAR PURPOSE, OR DESIGN OF SUCH PRODUCTS.

GSI SHALL NOT BE LIABLE FOR ANY DIRECT, INDIRECT, INCIDENTAL OR CONSEQUENTIAL DAMAGES, INCLUDING, WITHOUT LIMITATION, LOSS OF ANTICIPATED PROFITS OR BENEFITS. PURCHASER'S SOLE AND EXCLUSIVE REMEDY IS AS SET FORTH IN THE LIMITED WARRANTY EXPRESSED ABOVE, WHICH SHALL NOT EXCEED THE AMOUNT PAID FOR THE PRODUCT PURCHASED. THIS WARRANTY IS NOT TRANSFERABLE AND APPLIES ONLY TO THE ORIGINAL PURCHASER. GSI SHALL HAVE NO OBLIGATION OR RESPONSIBILITY FOR ANY REPRESENTATIONS OR WARRANTIES MADE BY OR ON BEHALF OF ANY DEALER, AGENT OR DISTRIBUTOR OF GSI.

GSI ASSUMES NO RESPONSIBILITY FOR CLAIMS RESULTING FROM ERECTION DEFECTS OR UNAUTHORIZED MODIFICATIONS TO PRODUCTS WHICH IT MANUFACTURED. MODIFICATIONS TO PRODUCTS NOT SPECIFICALLY DELINEATED IN THE MANUAL ACCOMPANYING THE EQUIPMENT AT INITIAL SALE WILL NULLIFY THE PRODUCT WARRANTY THAT MIGHT HAVE BEEN OTHERWISE AVAILABLE.

THE FOREGOING WARRANTY SHALL NOT EXTEND TO PRODUCTS OR PARTS WHICH HAVE BEEN DAMAGED BY NEGLIGENT USE, MISUSE, ALTERATION OR ACCIDENT. THIS WARRANTY EXTENDS SOLELY TO ONLY PRODUCTS MANUFACTURED BY GSI. THIS WARRANTY IS EXCLUSIVE AND IN LIEU OF ALL OTHER WARRANTIES EXPRESS OR IMPLIED. GSI RESERVES THE RIGHT TO MAKE DESIGN OR SPECIFICATION CHANGES AT ANY TIME.

PRIOR TO INSTALLATION, PURCHASER HAS THE RESPONSIBILITY TO COMPLY WITH ALL FEDERAL, STATE AND LOCAL CODES WHICH MAY APPLY TO THE LOCATION AND INSTALLATION OF PRODUCTS MANUFACTURED OR SOLD BY GSI.

---

---

This Equipment shall be installed in accordance with the current installation codes and applicable regulations which should be carefully followed in all cases. Authorities having jurisdiction should be consulted before installation occurs.

**For more information, contact the DMC Distribution Center closest to you.**

**Illiana Distribution Center**

1004 E. Illinois St.  
Assumption, Illinois 62510  
Phone: 217-226-5100  
FAX: 217-226-5070

**Clear Lake Distribution Center**

5205 4th Ave South  
Clear Lake, Iowa 50428  
Phone: 641-357-3386  
FAX: 641-357-1928

internet: <http://www.dmc-davidmanufacturing.com>