



Introduction

This kit is for the replacement of the mercury tilt switch with a Solid State Electronic Tilt Switch on the Design III Stir-Ator. This switch consists of an electronic controller (power supply and microprocessor) in a separate enclosure assembly and an accelerometer assembly.

On the Design III Stir-Ator, the electronic controller will be installed on the trolley mounted junction box bin center side mounting bracket. The accelerometer assembly will be installed in the tilt switch bracket in place of the mercury tilt switch. It can be manually adjusted by repositioning the bracket to adjust down auger trail-back in the same manner as the mercury switch. The Solid State Electronic Tilt Switch is powered by 230 volt and directly controls the 230 volt 1 phase power to the track drive motor.

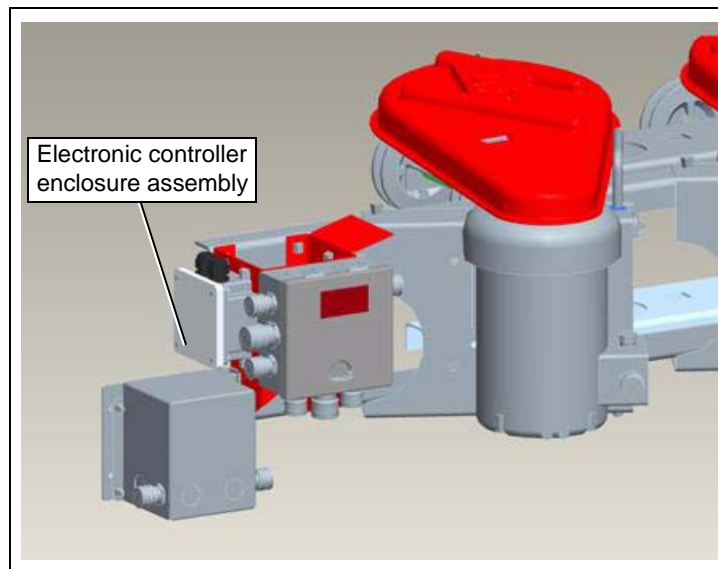

Figure 1

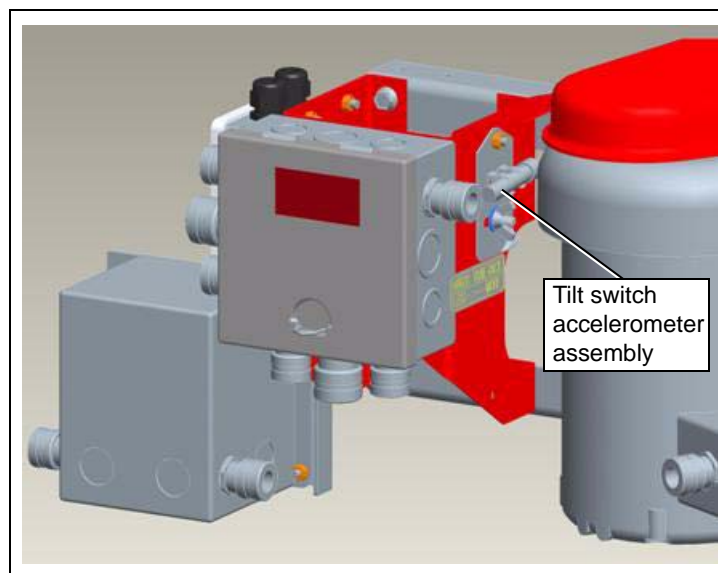

Figure 2



Solid State Electronic Tilt Switch for the Design III Stir-Ator

Service kit part numbers are:

106N322 - For Design III 230 volt 1 or 3 phase

106N323 - For Design III 460 volt 3 phase units

106N324 - For Design III 575 volt 3 phase units

The tilt switch electronic controller printed circuit board and the accelerometer assembly will be available for service as service kit part #106E110. These components will only be supplied as a matched set.

The kit for 575 volt units includes a mounting bracket and hardware to relocate the 575 volt to 230 volt transformer for the track drive motor from the track drive to the trolley. The kit for 460 volt units included a 460 volt to 230 volt transformer, mounting bracket and hardware and also a 230V motor to convert the track drive from 460 volt to 230 volt. These changes are necessary to provide 230 volt power for the Solid State Electronic Tilt Switch and allow the tilt switch to power the track drive motor. (Refer to PNOT-346 for additional information on the addition of or relocation of the transformer.) Installation instructions are included in the kits. The kit for the 230 volt units may also be used to replace the mercury tilt switch on older Stir-Ator units models 171 and 179 with a single mercury tilt switch (2 and 3 auger units).

Installation Instructions

1. Disconnect the electrical power to the Design III Stir-Ator at the shut off switch box mounted to the inside of the bin roof near the roof manhole opening before beginning the installation of the Solid State Electronic Tilt Switch.



Hazard of electrical shock or burn. Always disconnect the power before attempting to perform any service function. Follow lock out/tag out procedures as outlined in O.S.H.A. section 1910.147 where appropriate.



Electrical controls and wiring should be installed by a qualified electrician.

2. Layout and drill three (3) 9/32" diameter holes in the left hand (bin center side) trolley junction box mounting bracket to mount the solid state controller enclosure assembly. Use the dimensions shown in [Figure 3 on Page 3](#) or use the controller enclosure assembly as a template.
3. If the installation is on a 460 volt or 575 volt unit, layout and drill two (2) 9/32" diameter holes in the left hand (bin center side) trolley junction box mounting bracket to mount the transformer to power the Solid State Electronic Tilt Switch and the track drive motor. Use the dimensions shown in [Figure 3 on Page 3](#) or use the bracket, part #106E096 as a template.
4. Install the electronic controller enclosure assembly onto the left hand junction box mounting bracket using three (3) 1/4"-20 UNC x 5/8" flange bolts and three (3) 1/4"-20 UNC flange nuts. Remove the mercury tilt switch; route the accelerometer assembly electrical cord underneath the junction box and install the tilt switch accelerometer assembly into the tilt switch mounting bracket in place of the mercury tilt switch. Install the accelerometer assembly with the arrow on the side of the accelerometer aligned with the center of the opening of the mounting bracket clip and facing toward the front of the junction box. ([See Figure 4 on Page 3.](#)) **NOTE:** On Canadian CSA certified units, the tilt switch bracket may be relocated to the outside of the plastic junction box using the same mounting holes since mercury is no longer used. If it is desired to leave the tilt switch bracket inside the junction box, a 0.875" diameter hole must be drilled in an appropriate location in the side or bottom of the junction box for a 1EL0425 cable connector for routing of the accelerometer assembly electric cord into the junction box.

Installation Instructions (Continued)

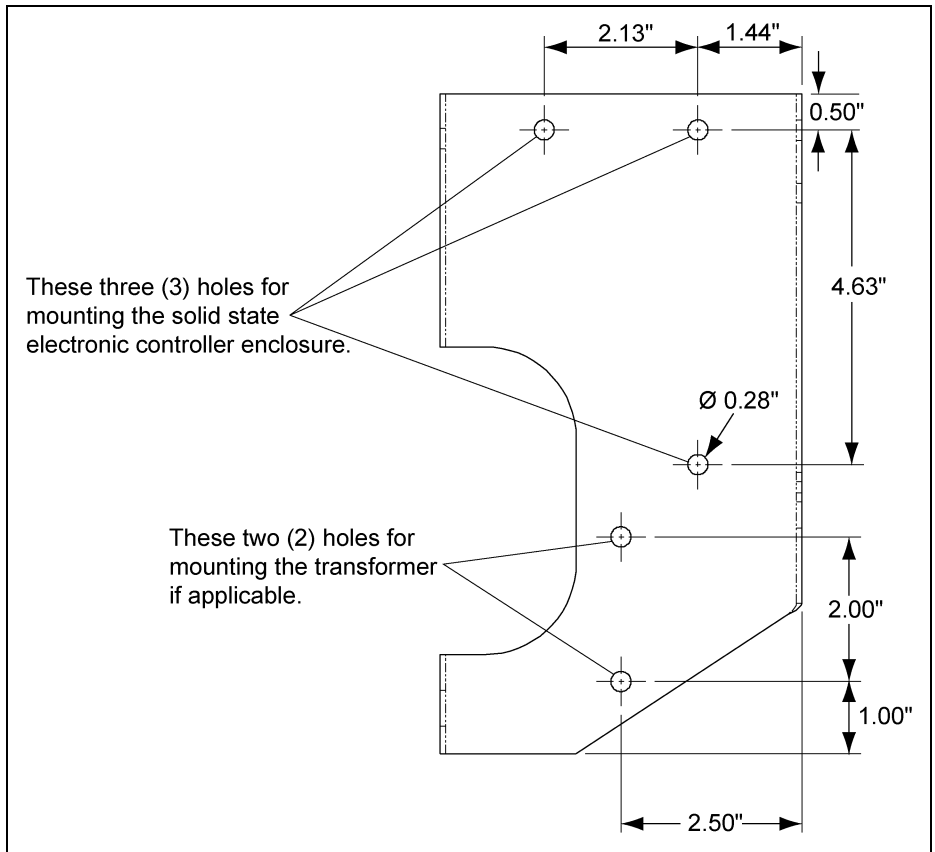

Figure 3 Drilled Hole Layouts

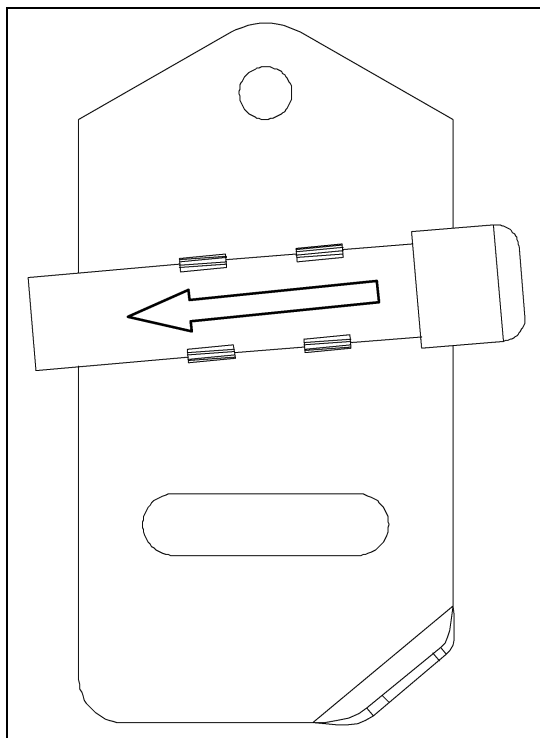

Figure 4 Accelerometer Installation

Installation Instructions (Continued)

5. Wire the electronic controller according to the voltage of the Design III Stir-Ator being retrofit. Refer to [Step 6](#) for 230 volt 1 phase and 3 phase, refer to [Step 7 on Page 5](#) for 460 volt 3 phase, and refer to [Step 8 on Page 6](#) for 575 volt 3 phase. Refer to [Wiring Diagrams on Pages 8-11](#) for the particular voltage for additional information. If the unit being retrofit is 460 volt or 575 volt and has a transformer for a 230 volt track drive motor already located on the trolley, refer to [Step 9 on Page 6](#).
6. Wiring for 230 volt 1 phase and 3 phase units:
 - a. Remove the bottom knockout from the left hand side of the junction box and install a cable connector, part #1EL0425. **NOTE:** *On Canadian CSA certified units, it will be necessary to drill an additional 7/8" diameter hole in the left (bin center) side of the plastic junction box to install the 1EL0425 cable connector.*
 - b. Route a wire part #106E101 (18/3) through this connector into the junction box and connect the black and white wires to the terminal block with the black and white wires from the main power cord. (**NOTE:** *The green wire in this 18/3 wire will not be used.*) Route the other end of this 18/3 wire (power-in) through the top, outer (right hand) cable connector on the electronic controller enclosure assembly and connect the black and white wires to the power connector (4 terminal) at the bottom of the printed circuit board. Connect the black wire to the terminal farthest to the right and connect the white wire to the inside terminal next to the black wire. ([See Figure 5.](#)) **NOTE:** *The top portion of the 4 terminal power connector pulls OFF for access.*

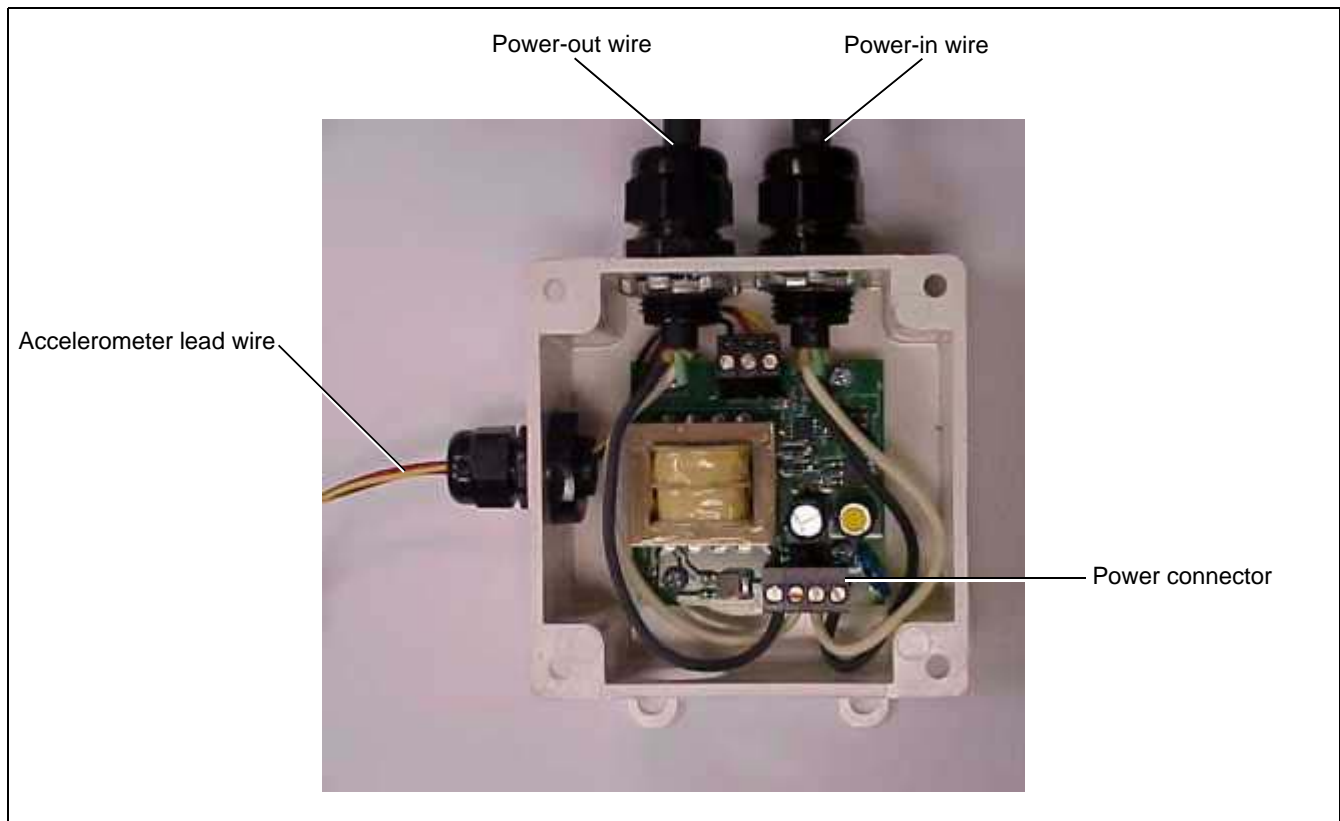

Figure 5 *Electronic Controller Enclosure Assembly Power Wire Routing*

Installation Instructions (Continued)

c. Remove the rubber grommet from the upper knockout hole on the right hand side of the junction box (where the mercury tilt switch lead wires previously entered the box) and install a cable connector, part #1EL0425. **NOTE:** *On Canadian CSA certified units, it will be necessary to drill an additional 7/8" diameter hole in the bottom of the plastic junction box to install the 1EL0425 cable connector.* Route a wire part #106E101 (18/3) through this connector into the junction box and connect the black and white wires with the black and white wires from the track drive motor power cord (black to black and white to white) using wire nuts. (**NOTE:** *The green wire in this 18/3 wire will not be used.*) The green wire of the track drive motor power cord should be connected to the terminal block with the green wire from the main power cord. Route the other end of this 18/3 wire (power-out) through the top, inner (left hand) cable connector on the electronic controller enclosure assembly and connect the black and white wires to the power connector at the bottom of the printed circuit board. Connect the black wire to the terminal farthest to the left and connect the white wire to the inside terminal next to the black wire. (See Figure 4 on Page 3.) **NOTE:** *Both white wires of the power-in and power-out 18/3 wires should be side by side.*

7. Wiring for 460 volt 3 phase units:

- a. Remove the 460 volt motor from the track drive gear motor assembly and replace it with 230 volt motor, part #3EL4006. Replace the 460 volt fuses in the track drive gear motor fuse holders with two (2) 230 volt fuses, part #1EL0727. Connect the lead wires of the new motor to the fuse holders. Refer to [460 Volt Wiring Diagram on Page 10](#).
- b. Attach the transformer, part #2EL0310, to bracket, part #106E096 using four (4) 1/4"-20 UNC x 5/8" flange bolts and four (4) 1/4"-20 UNC lock nuts.
- c. Assemble the bracket and transformer to the two (2) holes in the left hand trolley junction box mounting bracket that were drilled earlier.
- d. Remove the bottom knockout from the left hand side of the junction box and a knockout from each side of the transformer and install cable connectors, part #1EL0425.
- e. Remove the rubber grommet from the upper knockout hole on the right hand side of the junction box (where the mercury tilt switch lead wires previously entered the box) and install a cable connector, part #1EL0425.
- f. **NOTE:** *On Canadian CSA certified units, it will be necessary to drill two (2) additional 7/8" diameter holes in the left (bin center) side and bottom of the plastic junction box to install the 1EL0425 cable connectors.*
- g. Using three (3) of wire part #106E101 (18/3), wire from the junction box to the transformer, from the transformer to the electronic controller (outer (right hand) cable connector) and from the controller (top, inner (left hand) cable connector) back to the junction box following the 460V 3 phase wiring diagram. (See Page 10.) Connect the green wire in the 18/3 wire from the junction box to the transformer to the ground screw in the transformer (install a spade terminal, part #1EL0520, onto the green wire and connect the terminal to the ground screw).
- h. In the electronic controller enclosure assembly, connect the black and white wires to the power connector (4 terminal) at the bottom of the printed circuit board. The top portion of the 4 terminal power connector pulls OFF for access. Connect the power-in black wire to the terminal farthest to the right and connect the white wire to the inside terminal next to the black wire. Connect the power-out black wire to the terminal farthest to the left and connect the white wire to the inside terminal next to the black wire. Both white wires of the power-in and power-out 18/3 wires should be side by side. (See Figure 5 on Page 4.) **NOTE:** *The green wire in the 18/3 wires to and from the controller will not be used.*

Installation Instructions (Continued)

- i. In the junction box, connect the electronic controller power-out black and white wires to the black and white wires from the track drive motor power cord using wire nuts (black to black and white to white). The green wire of the track drive motor power cord should be connected to the terminal block with the green wire from the main power cord.
8. Wiring for 575 volt 3 phase units:
- a. Remove the transformer from the track drive assembly.
 - b. Connect the track drive power cord directly to the track drive fuse holders - refer to [575 Volt Wiring Diagram on Page 11](#).
 - c. Attach the transformer, part #2EL0310, to bracket, part #106E096 using four (4) 1/4"-20 UNC x 5/8" flange bolts and four (4) 1/4"-20 UNC lock nuts.
 - d. Assemble the bracket and transformer to the two (2) holes in the left hand trolley junction box mounting bracket that were drilled earlier.
 - e. Remove the bottom knockout from the left hand side of the junction box and install a cable connector, part #1EL0425.
 - f. Remove the rubber grommet from the upper knockout hole on the right hand side of the junction box (where the mercury tilt switch lead wires previously entered the box) and install a cable connector, part #1EL0425.
 - g. **NOTE:** *On Canadian CSA certified units, it will be necessary to drill two (2) additional 7/8" diameter holes in the left (bin center) side and bottom of the plastic junction box to install the 1EL0425 cable connectors.*
 - h. Using three (3) of wire part #106E101 (18/3), wire from the junction box to the transformer, from the transformer to the electronic controller (outer (right hand) cable connector) and from the controller (top, inner (left hand) cable connector) back to the junction box following the 460V 3 phase wiring diagram. ([See Page 10.](#)) Connect the green wire in the 18/3 wire from the junction box to the transformer to the ground screw in the transformer (install a spade terminal, part #1EL0520, onto the green wire and connect the terminal to the ground screw).
 - i. In the electronic controller enclosure assembly, connect the black and white wires to the power connector (4 terminal) at the bottom of the printed circuit board. The top portion of the 4 terminal power connector pulls OFF for access. Connect the power-in black wire to the terminal farthest to the right and connect the white wire to the inside terminal next to the black wire. Connect the power-out black wire to the terminal farthest to the left and connect the white wire to the inside terminal next to the black wire. Both white wires of the power-in and power-out 18/3 wires should be side by side. ([See Figure 5 on Page 4.](#)) **NOTE:** *The green wire in the 18/3 wires to and from the controller will not be used.*
 - j. In the junction box, connect the electronic controller power-out black and white wires to the black and white wires from the track drive motor power cord (black to black and white to white) using wire nuts. The green wire of the track drive motor power cord should be connected to the terminal block with the green wire from the main power cord.
9. Wiring for 460 volt 3 phase and 575 volt 3 phase units with the transformer already installed on the trolley:
- a. Remove the rubber grommet from the upper knockout hole on the right hand side of the junction box (where the mercury tilt switch lead wires previously entered the box) and install a cable connector, part #1EL0425. **NOTE:** *On Canadian CSA certified units, it will be necessary to drill an additional 7/8" diameter hole in the bottom of the plastic junction box to install the 1EL0425 cable connector.*

Installation Instructions (Continued)

- b. Disconnect the power-out 18/3 wire from the transformer and route it to the electronic controller (if this wire is too short, install a new wire part #106E101. In the electronic controller enclosure assembly, connect the black and white wires to the power connector (4 terminal) at the bottom of the printed circuit board. The top portion of the 4 terminal power connector pulls OFF for access. Connect the power-in black wire to the terminal farthest to the right and connect the white wire to the inside terminal next to the black wire. **NOTE:** *The green wire in this 18/3 wire will not be used.*
- c. Install an 18/3 wire part #106E101 into the electronic controller for power-out and connect the power-out black wire to the terminal farthest to the left and connect the white wire to the inside terminal next to the black wire. Both white wires of the power-in and power-out 18/3 wires should be side by side. **NOTE:** *The green wire in this 18/3 wires will not be used.*
- d. In the junction box, connect the electronic controller power-out black and white wires to the black and white wires from the track drive motor power cord (black to black and white to white) using wire nuts. The green wire of the track drive motor power cord should be connected to the terminal block with the green wire from the main power cord.

10. Adjustment procedure

- a. Once installed the Solid State Electronic Tilt Switch can be adjusted to adjust down auger trail-back by moving the tilt switch accelerometer assembly in the tilt switch mounting bracket in the same manner as the with the mercury tilt switch. Adjust the accelerometer to the right for more trail-back and to the left for less trail-back.
- b. In order to check the electronic tilt switch function and make trail-back adjustments, the electronic tilt switch must have power applied to the controller.



Failure to follow these instructions may result in injury or death.

- c. Turn OFF the main power at the shut off switch box mounted to the inside of the bin roof near the roof manhole opening.
- d. Disengage all the down auger belt drives on the trolley to prevent down auger operation and remove the fuses from the fuse holders in the track drive gear motor fuse box to prevent track drive operation.
- e. In the trolley junction box, connect a 230 volt test light or a voltmeter to the electronic tilt switch controller power-out black and white wires. There is also a red indicator light (LED) on the controller printed circuit board which will illuminate when the controller is ON and sending power to the track motor and may be used to observe power ON and OFF for trail-back adjustment. The cover of the controller enclosure must be removed to see this indicator light.
- f. Turn ON the main power at the shut off switch box mounted to the inside of the bin roof near the roof manhole opening to apply power to the Stir-Ator and the electronic tilt switch controller.
- g. Adjust down auger trail-back by observing the test light, voltmeter, or controller indicator light to determine when the track drive gear motor will turn ON.
- h. When adjustment is complete, disconnect power; remove the test light or voltmeter or re-install the cover on the controller enclosure; reengage the trolley down auger belt drives; and re-install the track drive gear motor fuses.

Solid State Electronic Tilt Switch for the Design III Stir-Ator

Wiring Diagrams

Design III Stir-Ator Wiring Diagram - 1 Phase - 230V - 60 Hz

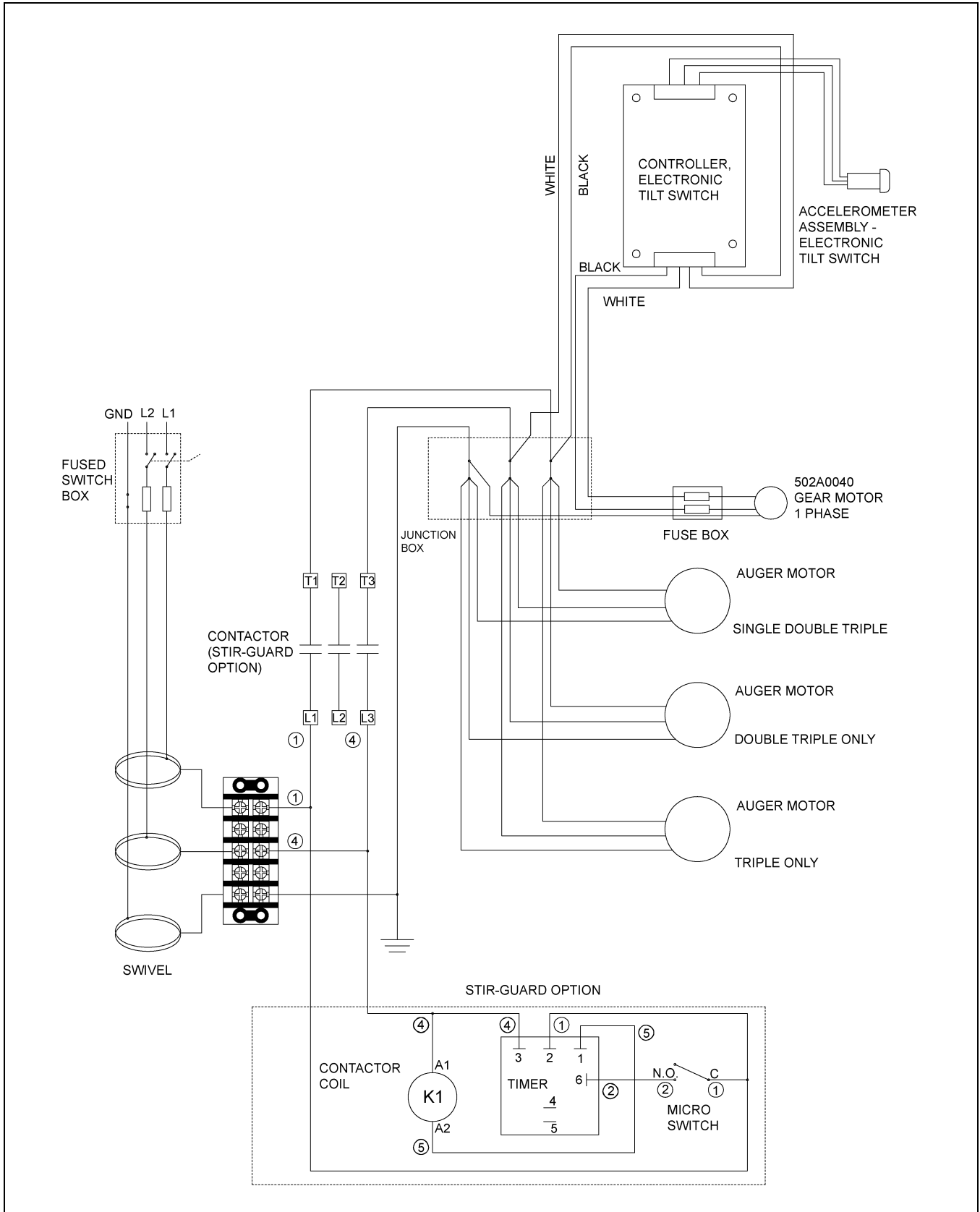

Solid State Electronic Tilt Switch for the Design III Stir-Ator

Design III Stir-Ator Wiring Diagram - 3 Phase - 230V - 60 Hz

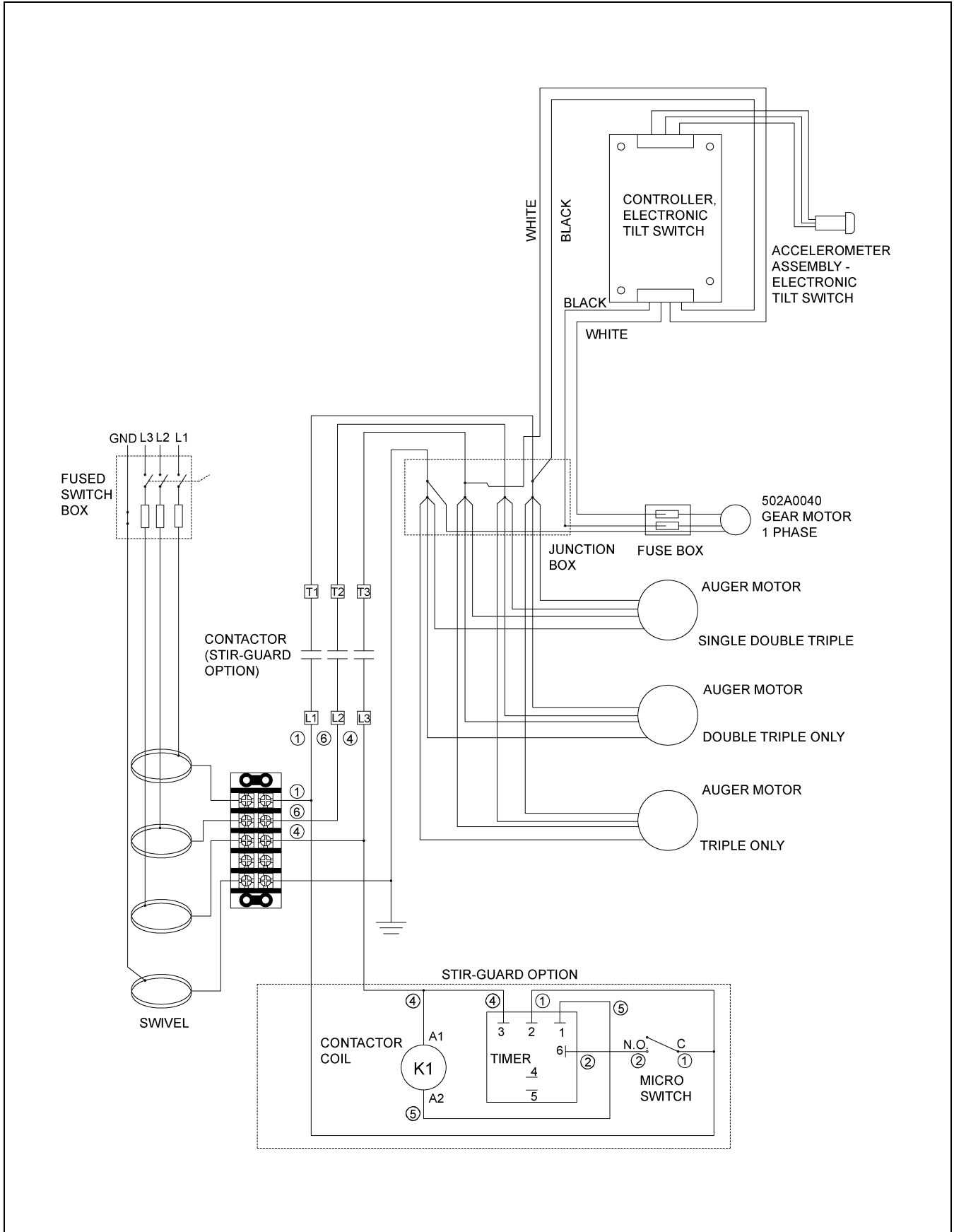

Solid State Electronic Tilt Switch for the Design III Stir-Ator

Design III Stir-Ator Wiring Diagram - 3 Phase - 460V - 60 Hz

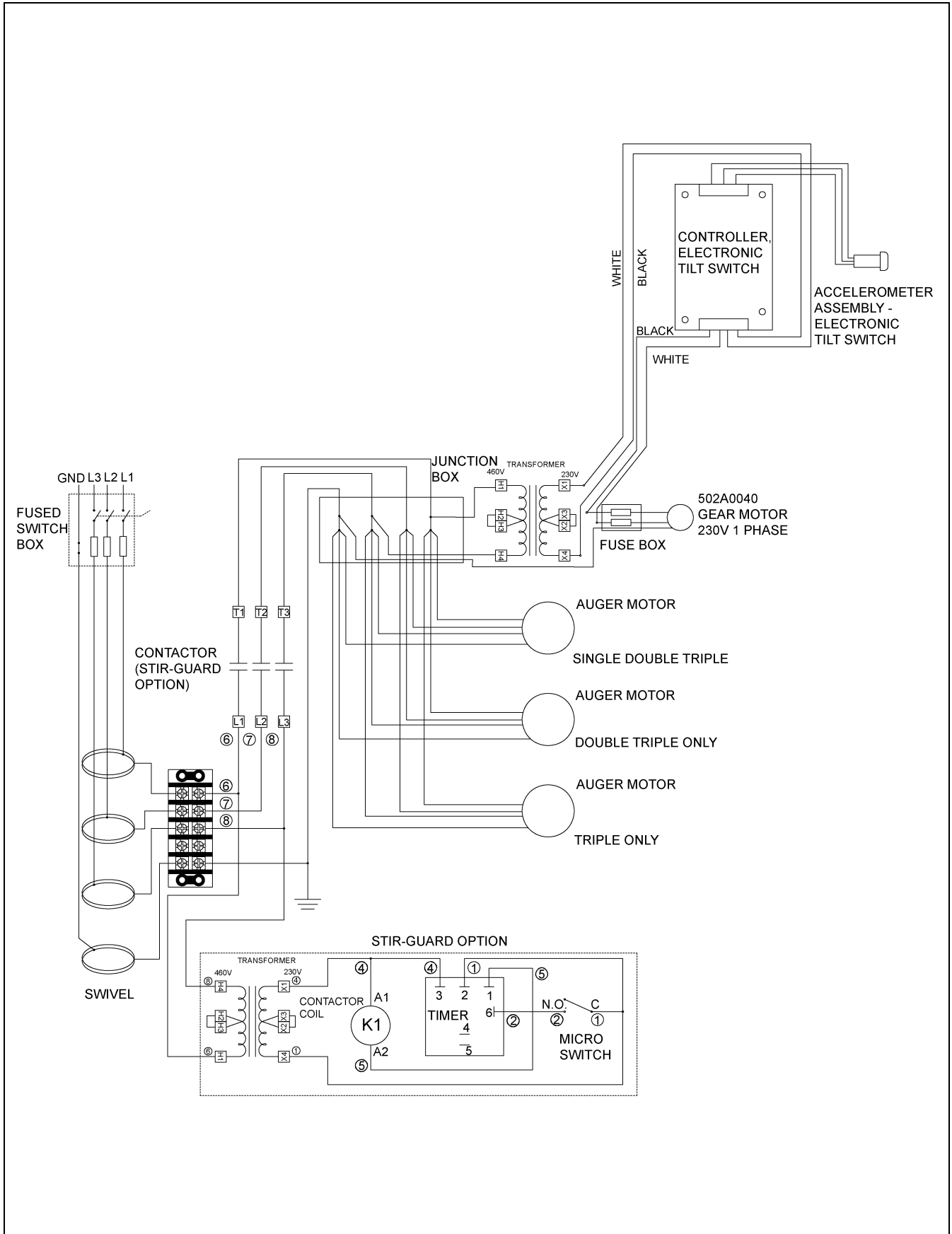

Design III Stir-Ator Wiring Diagram - 3 Phase - 575V - 60 Hz

